

Acta Cryst. (1971). B27, 1055

The Crystal and Molecular Structure of 2,5-Dithio-1-chloro-1-thiophosphorus(V) Cyclopentane

BY J. D. LEE AND G. W. GOODACRE

Department of Chemistry, University of Technology, Loughborough, Leicestershire, England

(Received 4 August 1970)

The crystal and molecular structure of 2,5-dithio-1-chloro-1-thiophosphorus(V) cyclopentane

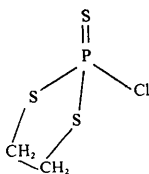

has been determined from X-ray data by the direct method of symbolic addition and has been refined by three-dimensional full-matrix least-squares methods. The unit cell is orthorhombic with space group $Pbca$ (D_{2h}^{15} no. 61), dimensions of $a = 11.095$, $b = 10.288$, $c = 12.739$ Å, and contains 8 molecules. The final R value based on 940 independent observed reflexions was 8.7%. The phosphorus atom is approximately tetrahedrally surrounded by three sulphur atoms and one chlorine atom. The two heterocyclic sulphur atoms both form P-S bonds of 2.051 ± 0.004 Å and ± 0.005 Å respectively. These are normal single bonds. The phosphorus atom forms a double bond of length 1.910 ± 0.005 Å to the third sulphur atom, and a single bond to chlorine of length 2.059 ± 0.004 Å. Two factors which distort the tetrahedral arrangement are the P=S bond and the inclusion of phosphorus in a five-membered heterocyclic ring. The heterocyclic ring is strained, with angles S-P-S = 100.5° , P-S-C = 94.1° , and 98.0° and S-C-C = 111.5° and 113.7° . In one molecule each chlorine atom receives two hydrogen bonds from other molecules, and two of the methylene hydrogen atoms are hydrogen bonded to chlorine atoms in other molecules. There is some further evidence that Pauling's value for the van der Waals radius of sulphur of 1.85 Å is too large, and a value of 1.72–1.73 Å is suggested.

Introduction

The determination of the structure of 2,5-dithio-1-chloro-1-thiophosphorus(V) cyclopentane was undertaken as part of an investigation of structures containing P-S bonds in this laboratory, and to confirm the structure and explain the nuclear magnetic resonance data for a group of new compounds of the type

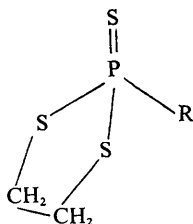

prepared by Professor R. Schmutzler and his co-workers (Technical University, Braunschweig, Germany).

Experimental

Colourless crystals of 2,5-dithio-1-chloro-1-thiophosphorus(V) cyclopentane were prepared and supplied by Dr S. C. Peake (Loughborough University). Recrystallization from a mixture of diethyl ether and petroleum ether gave crystals suitable for X-ray analysis in the form of pseudo-hexagonal blocks.

Crystals melted at 45°C , and showed straight extinction. Suitable crystals were mounted with shellac and Durofix on glass fibres, but after a number had come unstuck part way through a preliminary photographic investigation, or during the course of data collection on the diffractometer, it was decided to mount the crystal in a thin walled Pyrex capillary tube. It is suspected that the crystals came unstuck because of sublimation or hydrolysis with atmospheric moisture. Several crystals were rejected because there was evidence of twinning on Weissenberg photographs but eventually a crystal of approximate dimensions $0.28 \times 0.19 \times 0.19$ mm was used to collect data. Unit-cell dimensions were first calculated from high order reflexions on oscillation and Weissenberg photographs, and were refined on a Stöe diffractometer. Equi-inclination data were collected for the layers $0kl \rightarrow 11kl$ using a Stöe automatic diffractometer. Of the 1397 independent reflexions measured, 940 had $|F_o|$ values greater than twice their standard deviation of intensity and were treated as observed. The other reflexions were ignored, except for the symbolic addition procedure. Lorentz and polarization corrections were applied but no corrections were made for extinction or absorption.

Crystal data

$\text{ClS}_3\text{PC}_2\text{H}_4$, $M = 190.684$;
Orthorhombic, $a = 11.095$, $b = 10.288$, $c = 12.739$ Å
(all ± 0.003 Å);

$U = 1454.1 \text{ \AA}^3$, $F_{000} = 352$, $\lambda(\text{Cu } K\alpha) = 1.5418 \text{ \AA}$;
 $\mu(\text{Cu } K\alpha) = 134.6 \text{ cm}^{-1}$; $Z = 8$, $D_c = 1.742 \text{ g.cm}^{-3}$;
 $D_m = 1.75 \text{ g.cm}^{-3}$ (by flotation in a mixture of methyl
 iodide and carbon tetrachloride).

Absent reflexions:

hkl none, $0kl$ when k odd, $h0l$ when l odd,
 $hk0$ when h odd, $h00$ when h odd, $0k0$ when k odd,
 $00l$ when l odd. This uniquely determines the space
 group as $Pbca$ (D_{2h}^5 no. 61).

Structure determination

This structure was used to acquire experience with the automatic application of the direct method of phase determination. A set of computer programs for symbolic addition written by S. R. Hall and F. R. Ahmed as part of the NRC system of programs for the IBM 360 computer by Ahmed, Hall, Pippy & Huber (1966) were adapted for use on a 32K ICL 1905 computer.

Firstly the overall scale factor and overall temperature factor were estimated using a Wilson (1942) plot. Then normalized structure factors were calculated for all reflexions, and the 202 reflexions with $|E|$ values greater than 1.4 were sorted in descending order of $|E|$. The distribution statistics of the calculated normalized structure factor amplitudes $|E|$ are compared in Table 1 with the theoretical values for centrosymmetric and non-centrosymmetric structures as calculated by Karle, Hauptman, Karle & Wing (1958).

Phase determination by symbolic addition procedure for centrosymmetric structures was first applied by Karle & Karle (1963) and was subsequently described in more detail by Karle & Karle (1966). In the programs used the list of 70 reflexions having $|E|$ values greater than 2.0 were searched for triplets which obeyed the \sum_2 relationship. These were for use in the first stage of the sign determination. A second \sum_2 search was performed for triplets involving the full list of 202 reflexions with $|E|$ values of 1.4 and above, for use in the second stage of the sign determination.

Three linearly independent reflexions required to define the origin (Hauptman & Karle, 1953, 1959) were selected automatically by the computer program as the 587, 699 and 197 reflexions. These were the first, eighth and fourteenth reflexions respectively in the list of descending $|E|$ values. Their signs were assumed to be positive.

The signs of structure factors were estimated in two stages. In the first stage, the signs of the largest $|E|$ values (those above 2.0) were estimated using single E

triplets. When two reflexions of a triplet satisfying the \sum_2 relationship were signed, the tentative sign of the third reflexion was calculated as the product of the first two. In the early stages, tentative signs were accepted only if their probability was relatively high. The probability of the newly determined signs was calculated from the sums

$$\sum_{\mathbf{k}} \sigma_3 \sigma_2^{-3/2} |E_{\mathbf{h}}| E_{\mathbf{k}} E_{\mathbf{h}-\mathbf{k}}$$

rather than the full probability expression given by Woolfson (1954) and Cochran & Woolfson (1955):

$$P + (h) \simeq \frac{1}{2} + \frac{1}{2} \tanh (\sigma_3 \sigma_2^{-3/2} |E_{\mathbf{h}}| \sum_{\mathbf{k}} E_{\mathbf{k}} E_{\mathbf{h}-\mathbf{k}}).$$

The term $\sigma_3 \sigma_2^{-3/2}$ may be calculated from the equations:

$$\sigma_2 = \sum_j Z_j^2$$

$$\sigma_3 = \sum_j Z_j^3$$

where the sum is over all the atoms in the full unit cell, and Z_j is the atomic number of atom j . For this structure the value of $\sigma_3 \sigma_2^{-3/2}$ was 0.148.

An automated procedure searched for triplets involving two of the three origin defining reflexions and one other reflexion, in an attempt to find a tentative sign for the unsigned reflexion. The minimum acceptable probability limit was reduced in steps from 8.0 to 7.5 to 7.0. The search was repeated after each step with the reflexions with acceptable tentative signs included in the list of signed reflexions. When no more tentative signs could be accepted, a strong reflexion with a large number of associated E pairs was assigned the symbol A , and the search for acceptable tentative signs was repeated with this reflexion added to the list. The probability limit was reduced in steps from 6.5 to 6.0 to 5.5. In the same way two more symbols B and C were assigned when necessary, with probability limits set at 5.0, 4.5 and 4.0 for symbol B , and 3.5, 3.0 and 2.5 for symbol C . The minimum acceptable limit used was 2.4, which corresponds to a probability of greater than 98%. From the accumulated information about the signs of the 70 reflexions it was obvious that the sign of A was +, B was - and C was -. This gave the signs of 65 of the 70 reflexions, without giving any contradictions in the \sum_2 relationships between them.

In the second stage of the estimation of structure-factor signs, the signs of the largest $|E|$ values already determined were applied directly to \sum_2 related triplet sets associated with smaller $|E|$ values (down to 1.4).

Table 1. Distribution statistics of the $|E|$ amplitudes

	Calculated for this structure	Theoretical for centrosymmetric	Theoretical for non-centrosymmetric
$\langle E \rangle$	0.790	0.798	0.886
$\langle E^2 \rangle$	1.005	1.000	1.000
$\langle E^2 - 1 \rangle$	0.981	0.968	0.736
$ E > 3$	0.4%	0.3%	0.01%
$ E > 2$	5.0	5.0	1.8
$ E > 1$	30.4	32.0	37.0

Table 2. *Final atomic coordinates and their estimated standard deviations*

Atom	x/a	$\sigma(x/a)$	y/b	$\sigma(y/b)$	z/c	$\sigma(z/c)$
Cl	0.0086	0.0003	0.2349	0.0004	0.5729	0.0002
S(1)	0.0533	0.0003	0.3999	0.0003	0.3605	0.0002
S(2)	-0.1217	0.0004	0.1587	0.0003	0.3515	0.0003
S(3)	0.1764	0.0004	0.1024	0.0003	0.3899	0.0003
P	0.0408	0.0003	0.2127	0.0002	0.4148	0.0002
C(1)	-0.1078	0.0013	0.4277	0.0013	0.3650	0.0009
C(2)	-0.1750	0.0014	0.3210	0.0013	0.3144	0.0010

The minimum acceptable limit was set at 1.75, which corresponds to a probability of 97%. This produced signs for 109 of the 132 reflexions with $|E|$ between 2.0 and 1.4. An E map was computed with the total of 174 signed reflexions, and gave unambiguous positions for the chlorine, phosphorus and sulphur atoms and possible positions for the carbon atoms.

Structure refinement

Calculations were carried out on a 32K ICL 1905 computer, using the Loughborough University X-ray (*LUX*) system of FORTRAN programs which comprises adaptations of many of the well known NRC programs (Ahmed, Hall, Pippy & Huber, 1966), a substantially rewritten and extended version of the full-matrix least-squares program *ORFLS* (Busing, Martin & Levy, 1962) called *LEE-ORFLS*, together with programs of local origin.

A structure factor calculation was performed on the Cl, S and P atoms in the positions suggested by the E map, using scattering factors (Hanson, Herman, Lea & Skillman, 1964) corrected for the real part of anomalous dispersion (Dauben & Templeton, 1955) and an overall scale factor obtained from a Wilson plot. The initial agreement factor of $R=37.3\%$ fell to 27.9% after one cycle of refinement using unit weights.

Carbon atoms were located on a heavy atom Fourier synthesis, and when included in a structure factor calculation, R reduced to 19.8%. In subsequent cycles of least-squares a Cruickshank type of weighting scheme was introduced:

$$w = \frac{1}{A + B|F_o| + C|F_o^2|}$$

The Cl, P and S atoms were allowed to refine anisotropically, and when R reached 11.4% the positions of hydrogen atoms were calculated at a distance of 1.075 Å

from the carbon atoms to which they are attached. These positions were verified by a difference Fourier synthesis. The H atoms were included in the calculations with an isotropic temperature factor of $B=6.0 \text{ \AA}^2$, but the H parameters were not refined. The C atoms were then allowed to refine anisotropically, and new H positions calculated. A bond length and angle calculation included in the least-squares program was used to check that the refined atomic positions were reasonable at each stage, and an agreement analysis is also included automatically. Data from the latter were used in a computer program by Lee & Goodacre (1970a) to calculate new values for the weight constants A , B and C after each least-squares run. In the later stages one reflexion 912 which consistently had a large value of $\sqrt{w}\Delta F$ was excluded from the least-squares matrix, but not from the calculation of R . The final values for the weight constants used were $A=2.2453$, $B=-0.1534$ and $C=0.0047$. The introduction of a negative value for B causes the weight/ F_{obs} curve to pass through a maximum, and prevents extremely weak reflexions with a large experimental error being given excessively high weights. Refinement converged at $R=8.7\%$ based on 940 independent observed reflexions. A difference Fourier synthesis revealed no unexplained features.

The signs of the 174 reflexions predicted by the symbolic addition procedure were compared with the final calculated signs, and all but one of the predicted signs were correct.

Table 3. *Calculated positions of hydrogen atoms*

Atom	Bonded to	x/a	y/b	z/c
H(1)	C(1)	-0.1357	0.4351	0.4456
H(11)	C(1)	-0.1280	0.5171	0.3250
H(2)	C(2)	-0.1663	0.3312	0.2307
H(22)	C(2)	-0.2683	0.3292	0.3361

The hydrogen atoms were assigned an isotropic temperature factor of $B=6.0 \text{ \AA}^2$.

Table 4. *Final temperature factor parameters*

$$\text{TF} = \exp \{ -[h^2\beta_{11} + k^2\beta_{22} + l^2\beta_{33} + 2hk\beta_{12} + 2hl\beta_{13} + 2kl\beta_{23}] \}$$

Atom	β_{11}	β_{22}	β_{33}	β_{12}	β_{13}	β_{23}
Cl	0.0170	0.0183	0.0038	0.0002	0.0011	0.0018
S(1)	0.0137	0.0073	0.0058	-0.0016	0.0004	0.0011
S(2)	0.0148	0.0099	0.0110	-0.0035	-0.0045	0.0008
S(3)	0.0151	0.0119	0.0085	0.0043	-0.0012	-0.0018
P	0.0105	0.0067	0.0042	-0.0006	-0.0005	-0.0002
C(1)	0.0143	0.0122	0.0067	0.0034	-0.0014	-0.0019
C(2)	0.0147	0.0128	0.0068	0.0021	-0.0009	0.0001

Table 5. Observed and calculated structure factors

h	k	l	F _o	F _c	h	k	l	F _o	F _c	h	k	l	F _o	F _c	h	k	l	F _o	F _c	h	k	l	F _o	F _c	h	k	l	F _o	F _c	h	k	l	F _o	F _c	h	k	l	F _o	F _c	h	k	l	F _o	F _c					
0	0	0	304.3	383.5	1	4	3	26.8	-24.9	2	4	1	43.1	-45.5	3	3	3	13.2	13.6	4	3	3	13.2	13.7	-37.3	4	3	10	41.1	44.4	5	4	10	15.3	-14.4	6	6	10	8.3	-7.8	8	2	7.4	7.6	9	8	6	5.3	3.4
0	0	0	91.4	-87.2	1	3	4	9.8	43.6	2	7	1	39.4	41.4	3	4	13	10.1	10.7	4	3	12	12.4	12.7	4	3	10	8.2	-6.8	5	10	14.0	-11.2	6	2	11	15.6	-15.7	8	2	9.0	-9.4	9	1	7	16.1	-14.9		
0	0	0	81.3	-77.2	1	3	3	9.8	-39.9	2	8	1	24.6	-24.1	3	6	13	13.2	-11.1	4	3	12	13.9	8.3	4	3	10	8.2	-6.8	5	11	11.0	9.6	6	2	11	15.1	13.9	8	2	7.2	5.0	9	2	7	19.2	-16.8		
0	0	0	71.0	69.0	1	3	2	18.9	19.5	2	12	1	16.6	15.3	3	0	14	36.1	32.3	4	3	13	8.4	-8.2	4	3	10	10.7	23.1	5	6	11	11.0	9.6	6	1	12	22.3	-19.3	8	2	3	11.6	11.4	9	3	7	14.9	15.4
0	0	0	19.3	21.2	1	3	4	14.0	-14.0	2	2	2	74.5	95.2	3	2	14	23.6	-23.9	4	3	13	11.5	-9.6	4	3	10	8.2	-6.8	5	12	13.6	-10.8	6	2	12	15.2	-15.2	8	2	3	10.8	10.0	9	4	7	11.7	12.7	
0	0	0	7.0	4.0	1	4	1	6.4	-14.0	2	4	1	6.4	-14.0	3	1	16	6.9	7.4	4	3	14	15.4	15.1	4	3	10	8.2	-6.8	5	13	10.1	9.6	6	2	13	16.0	-16.0	8	2	4	10.2	-9.9	9	3	8	6.1	5.3	
0	0	0	27.3	-26.1	1	0	4	95.8	93.6	2	2	2	96.1	-105.9	3	1	15	11.2	-7.9	4	3	14	15.0	12.9	4	3	10	8.2	-6.8	5	14	13.2	12.6	6	2	14	16.2	-16.2	8	2	5	10.1	-10.7	9	3	7	10.3	-10.6	
0	0	0	9.6	-6.7	1	0	4	80.1	-79.2	2	2	2	13.5	-13.9	3	2	15	7.8	-4.7	4	3	14	8.5	-9.0	4	3	10	8.2	-6.8	5	15	14.6	-14.6	6	2	15	16.6	-16.6	8	2	6	10.8	11.7	9	3	8	24.4	21.7	
0	0	0	15.8	15.4	1	2	4	27.2	-27.2	2	2	2	67.9	67.9	3	1	16	9.5	7.4	4	3	14	9.5	7.4	4	3	10	8.2	-6.8	5	16	14.8	-14.8	6	2	16	13.8	-13.8	8	2	7	15.2	17.7	9	2	8	1.5	9.7	
0	0	0	36.0	34.5	1	3	4	9.7	7.4	2	3	2	12.1	-12.0	3	2	17	5.1	-53.5	4	3	15	10.6	-92.8	4	3	10	8.2	-6.8	5	17	14.2	-14.2	6	2	17	16.0	-16.0	8	2	8	14.1	-14.0	9	3	8	11.8	-12.0	
0	0	0	76.1	-77.3	1	4	4	20.5	-49.7	2	6	2	61.1	-59.7	3	4	1	21.6	-25.8	4	3	16	10.9	-21.8	4	3	10	8.2	-6.8	5	18	14.6	-14.6	6	2	18	16.7	-16.7	8	2	9	14.0	-13.7	9	4	8	7.1	-5.8	
0	0	0	82.9	81.4	1	4	3	13.4	15.2	2	7	2	10.4	-11.9	3	2	18	6.7	6.9	4	3	17	8.5	-9.8	4	3	10	8.2	-6.8	5	19	14.8	-14.8	6	2	19	16.3	-16.3	8	2	3	15.2	17.7	9	2	8	5.3	-5.3	
0	0	0	50.4	-46.2	1	7	4	19.2	20.0	2	1	3	28.3	-33.1	3	1	19	6.6	65.3	4	3	18	10.7	10.6	4	3	10	8.2	-6.8	5	20	14.2	-14.2	6	2	20	16.3	-16.3	8	2	4	19.6	19.8	9	2	8	5.9	4.4	
0	0	0	10.5	10.2	1	8	4	43.6	-23.5	2	3	2	63.4	65.7	3	7	1	42.5	40.3	4	3	19	11.1	10.7	4	3	10	8.2	-6.8	5	21	14.9	-14.9	6	2	21	16.5	-16.5	8	2	1	26.5	29.0	9	1	4	14.3	11.7	
0	0	0	8.5	-8.0	1	11	4	19.1	19.2	2	4	3	45.7	50.9	3	8	1	18.9	-19.2	4	3	20	12.0	-22.1	4	3	10	8.2	-6.8	5	22	14.9	-14.9	6	2	22	16.5	-16.5	8	2	2	19.8	19.9	9	2	8	4.7	-4.7	
0	0	0	75.0	-76.9	1	13	5	23.3	-23.3	2	5	3	10.3	-9.8	3	9	1	15.5	-12.3	4	3	21	13.5	12.3	4	3	10	8.2	-6.8	5	23	14.8	-14.8	6	2	23	16.5	-16.5	8	2	3	19.8	19.9	9	2	9	10.0	-12.2	
0	0	0	63.5	62.0	1	13	3	42.0	-42.0	2	6	3	40.0	-37.1	3	12	1	10.7	-10.8	4	3	22	15.0	14.4	4	3	10	8.2	-6.8	5	24	14.8	-14.8	6	2	24	16.5	-16.5	8	2	4	18.8	18.8	9	0	10	11.4	-12.5	
0	0	0	16.8	-16.9	1	13	3	39.1	-36.3	2	7	3	40.0	-37.1	3	12	1	10.7	-10.8	4	3	23	15.3	13.3	4	3	10	8.2	-6.8	5	25	14.8	-14.8	6	2	25	16.5	-16.5	8	2	5	20.2	20.2	9	1	10	10.9	10.3	
0	0	0	16.1	14.0	1	14	4	29.4	-29.4	2	8	3	24.8	-23.4	3	13	1	11.5	-11.0	4	3	24	15.6	14.4	4	3	10	8.2	-6.8	5	26	14.8	-14.8	6	2	26	16.5	-16.5	8	2	6	19.9	19.9	9	3	10	12.5	-13.6	
0	0	0	12.5	-11.6	1	14	3	38.2	-39.4	2	9	3	21.1	-21.1	3	14	1	11.5	-11.3	4	3	25	15.8	14.4	4	3	10	8.2	-6.8	5	27	14.8	-14.8	6	2	27	16.5	-16.5	8	2	7	20.2	20.2	9	3	10	15.6	-16.5	
0	0	0	32.1	31.0	1	15	3	38.2	-39.4	2	10	3	7.8	7.5	3	15	2	10.3	-10.3	4	3	26	16.2	14.4	4	3	10	8.2	-6.8	5	28	14.8	-14.8	6	2	28	16.5	-16.5	8	2	8	19.7	19.7	9	2	10	14.4	7.5	
0	0	0	32.1	-30.1	1	15	3	23.5	-23.5	2	10	3	15.0	15.5	3	16	2	12.2	-11.3	4	3	27	16.5	14.4	4	3	10	8.2	-6.8	5	29	14.8	-14.8	6	2	29	16.5	-16.5	8	2	9	19.7	19.7	9	1	11	11.1	9.3	
0	0	0	100.8	97.5	1	15	3	12.7	-8.9	2	11	4	21.5	23.9	3	17	3	20.0	19.7	4	3	28	16.8	15.0	4	3	10	8.2	-6.8	5	30	14.8	-14.8	6	2	30	16.5	-16.5	8	2	10	20.2	20.2	9	3	11	11.1	9.3	
0	0	0	59.1	56.9	1	15	3	9.6	-12.2	2	12	4	26.7	-26.7	3	18	3	23.8	23.9	4	3	29	17.0	15.2	4	3	10	8.2	-6.8	5	31	14.8	-14.8	6	2	31	16.5	-16.5	8	2	11	20.2	20.2	9	3	11	11.1	9.3	
0	0	0	34.1	-32.9	1	16	4	6.5	-45.1	-29.2	2	13	4	23.2	-23.2	3	19	3	22.5	-22.5	4	3	30	17.1	15.3	4	3	10	8.2	-6.8	5	32	14.8	-14.8	6	2	32	16.5	-16.5	8	2	12	20.2	20.2	9	3	12	11.1	9.3
0	0	0	7.4	-6.9	1	16	4	10.3	-9.9	2	14	4	23.2	-23.2	3	20	3	22.2	-22.2	4	3	31	17.2	15.4	4	3	10	8.2	-6.8	5	33	14.8	-14.8	6	2	33	16.5	-16.5	8	2	13	20.2	20.2	9	3	13	11.1	9.3	
0	0	0	80.5	55.7	1	16	4	46.6	-52.9	2	14	4	31.2	30.8	3	21	2	11.2	-11.0	4	3	32	17.3	15.6	4	3	10	8.2	-6.8	5	34	14.8	-14.8	6	2	34	16.5	-16.5	8	2	14	20.2	20.2	9	3	14	11.1	9.3	
0	0	0	14.4	-14.6	1	16	4	33.5	27.8	2	15	4	66.4	-63.5	3	22	3	70.4	-67.4	4	3	33	17.4	15.7	4	3	10	8.2	-6.8	5	35	14.8	-14.8	6	2	35	16.5	-16.5	8	2	15	20.2	20.2	9	3	15	11.1	9.3	
0	0	0	78.3	-77.3	1	16	4	37.9	38.4	2	15	4	29.4	-29.4	3	23	3	100.9	102.0	4	3	34	17.5	15.8	4	3	10	8.2	-6.8	5	36	14.8	-14.8	6	2	36	16.5	-16.5	8	2	16	20.2	20.2	9	3	16	11.1	9.3	
0	0	0	101.3	101.6	1	16	4	76.0	-37.0	2	16	4	16.4	-14.0	3	24	3	50.7	49.7	4	3	35	17.6	15.9	4	3	10	8.2	-6.8	5	37	14.8	-14.8	6	2	37	16.5	-16.5	8	2	17	20.2	20.2	9	3	17	11.1	9.3	
0	0	0	108.0	101.6	1	16	4	12.0	-14.0	2	17	4	33.0	30.7	3	25	3	18.7	-16.6	4	3	36	17.7	16.0	4	3	10	8.2	-6.8	5	38	14.8	-14.8	6	2	38	16.5	-16.5	8	2	18	20.2	20.2	9	3	18	11.1	9.3	
0	0	0	59.4	59.7	1	16	4	26.0	-24.4	2	17	4	34.0	34.4	3	26	3	21.5	-19.5	4	3	37	17.8	16.1	4	3	10	8.2	-6.8	5	39	14.8	-14.8	6	2	39	16.5	-16.5	8	2	19	20.2	20.2	9	3	19	11.1	9.3	
0	0	0	18.9	-18.9	1	17	5	20.5	-21.4	2	18	5	46.1	-55.9	3	27	4	38.1	-40.8	4	3	38	17.9	16.4	4	3	10	8.2	-6.8	5	40	14.8	-14.8	6	2	40	16.												

Discussion

A view of one molecule is shown in Fig. 1, and the packing of molecules in the unit cell as seen down [001] is given in Fig. 2. Bond lengths and bond angles together with their estimated standard deviations are given in Tables 7 and 8.

Table 7. Bond lengths and their standard deviations

Bond	Distance	σ
P—Cl	2.059 Å	0.004 Å
P—S(1)	2.051	0.004
P—S(2)	2.051	0.005
P—S(3)	1.910	0.005
S(1)—C(1)	1.812	0.015
S(2)—C(2)	1.834	0.014
C(1)—C(2)	1.475	0.019

Table 8. Bond angles and their standard deviations

	Angle	σ
S(3)—P—S(1)	116.7°	0.2°
S(3)—P—S(2)	117.8	0.2
S(3)—P—Cl	111.4	0.2
S(1)—P—S(2)	100.5	0.2
S(1)—P—Cl	103.7	0.2
S(2)—P—Cl	105.2	0.2
S(1)—C(1)—C(2)	111.5	1.0
S(2)—C(2)—C(1)	113.7	1.0
P—S(1)—C(1)	94.1	0.4
P—S(2)—C(2)	98.0	0.5

The phosphorus atom is approximately tetrahedrally surrounded by the atoms S(1), S(2), S(3) and Cl. The bond lengths P—S(1) and P—S(2) are both 2.051 Å with standard deviations of 0.004 and 0.005 Å respectively. The sum of Pauling's (1960) single-bonded covalent radii (P = 1.10 Å, S = 1.04 Å) is 2.14 Å and even if this distance is corrected for the electronegativity difference between the atoms (Schomaker & Stevenson, 1941) the predicted distance is still 2.116 Å — appreciably longer than the observed values. The bond P—S(3) of 1.910 ± 0.005 Å is shortened by back bonding from a full *p* orbital on the sulphur to an empty *d* orbital on the phosphorus. This value may be compared with the sum of Pauling's double bonded radii of 1.94 Å which when

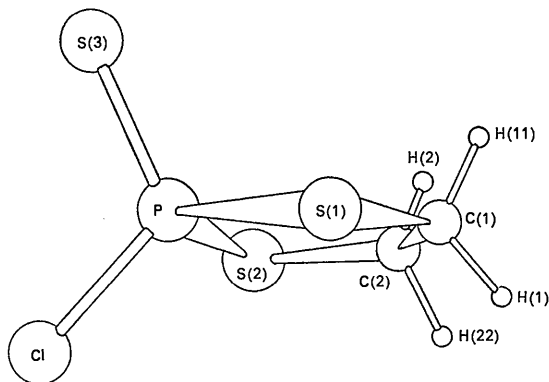

Fig. 1. A view of one molecule.

corrected for the difference in electronegativity becomes 1.916 Å. This is only about one standard deviation from the observed value. The P=S distances in a number of other compounds are appreciably longer than this [1.98 Å in dimethyldiphenyldiphosphine disulphide (Wheatley, 1960), 1.94 Å in tetraethyldiphosphine disulphide (Dutta & Woolfson, 1961), 1.95 Å in bis(cyclotetramethylene)diphosphine disulphide (Lee & Goodacre, 1969), 1.95 Å in bis(cyclopentamethylene)diphosphine disulphide (Lee & Goodacre, 1970*b*) and 1.95 and 1.97 Å in tetramethyldiphosphine disulphide (Lee & Goodacre, 1971)]. It seems likely that the shortened P—S and P=S bonds arise because the high electronegativity of chlorine localizes the orbitals on the phosphorus atom and allows more effective overlap. The P—Cl bond of 2.059 ± 0.004 Å is appreciably shorter than the sum of Pauling's (1960) radii of 2.09 Å, but longer than the electronegativity corrected value of 2.036 Å. The observed bond length is also greater than the value of 2.02 Å in thiophosphoryl chloride (Williams, Sheridan & Gordy, 1952).

The distribution of bonds round the phosphorus atom is essentially tetrahedral, but two factors which cause a certain amount of distortion are the P=S bond and the inclusion of phosphorus in a heterocyclic ring. The three angles S(3)—P—S(1), S(3)—P—S(2) and S(3)—P—Cl are all greater than tetrahedral (116.7°, 117.8° and 111.4° respectively) whilst the remaining three bond angles round the phosphorus atom S(1)—P—S(2), S(1)—P—Cl and S(2)—P—Cl are less than tetrahedral (100.5, 103.7 and 105.2° respectively). Because of π -bonding, S(3) is rather close to the phosphorus atom, hence repulsive forces to the other three atoms bonded to the phosphorus atom account for this distortion. The angle S(1)—P—S(2) is reduced more than the others, and this further distortion arises from the inclusion of two bonds from a phosphorus atom in a five-membered heterocyclic ring system. Similar distortions due to P=S have been observed in the diphosphine disulphide compounds listed above, and the inclusion of two bonds from a phosphorus atom in a heterocyclic ring reduces the corresponding angle to 96.6° in bis(cyclotetramethylene)diphosphine disulphide for a five-membered heterocyclic ring, and 101.8° for a similar but less strained six-membered heterocyclic ring in bis(cyclopentamethylene)diphosphine disulphide.

The S—C distances of 1.81 and 1.83 Å are in reasonable agreement with the sum of Pauling's single bonded radii of 1.812 Å, the value of 1.8177 Å in methanethiol CH₃SH (Kilb, 1955) and the average paraffinic C—S value of 1.81₅ Å (Sutton, 1958).

The C(1)—C(2) distance of 1.47₅ Å is less than the normal single bond distance, and the angles S(1)—C(1)—C(2) and S(2)—C(2)—C(1) of 111.5° and 113.7° are greater than the expected tetrahedral value. These distortions arise from strain in the heterocyclic ring. As might be expected, the heterocyclic ring is puckered. The equation to the best plane through the ring calculated by the method of Schomaker, Waser, Marsh &

Bergman (1959) together with the distance of each atom from the plane, are shown in Table 9.

Table 9. *Best least-squares plane through the heterocyclic ring*

Atoms in plane	Equation to plane
P, S(1), S(2), C(1), C(2)	$-3.41X + 1.09Y + 12.05Z = 4.89$
(X, Y and Z refer to the unit-cell axes a, b and c.)	
Distances of atoms from the plane	
P	-0.194 Å
S(1)	0.299
S(2)	0.071
C(1)	-0.336
C(2)	0.161

A complete bond scan of all the interatomic distances of up to 4.0 Å was performed, and all the approaches less than the sum of the appropriate van der Waals radii were examined. These are considered in three groups. Firstly, the non-bonded approaches which are short and occur within the molecule are listed in Table 10, taking the Pauling (1960) values for van der Waals radii of atoms as Cl = 1.80 Å, S = 1.85, P = 1.9, CH₂ = 2.0 and H = 1.2 Å. These are all unavoidable distances across rings, *etc.* and show no special features. Secondly the short intermolecular approaches involving a sulphur atom are listed in Table 11(a). It is apparent that these are only slightly short. Recently a number of workers have suggested that the van der Waals radius of sulphur should be 1.72–1.73 Å (Fava Gasparri, Nardelli & Villa, 1967; Nardelli, Fava Gasparri, Giraldo Battistini & Domiano, 1966; Ždanov & Zvonkova, 1950; Van der Helm, Lessor & Merritt, 1960; Lee &

Bryant, 1969a, b). If the smaller van der Waals radius is accepted, then all of these distances become normal.

Table 10. *Distances less than the sum of the van der Waals radii which occur within one molecule*

Cl·····S(1)	3.23 Å
Cl·····S(2)	3.27
Cl·····S(3)	3.28
Cl·····C(1)	3.55
S(1)····S(2)	3.15
S(1)····S(3)	3.37
S(1)····C(2)	2.72
S(1)····H(1)	2.39
S(1)····H(11)	2.39
S(1)····H(2)	3.03
S(2)····S(3)	3.39
S(2)····C(1)	2.78
S(2)····H(2)	2.40
S(2)····H(22)	2.40
P·····C(1)	2.83
P·····C(2)	2.94
P·····H(1)	3.04
C(1)····H(2)	2.08
C(1)····H(22)	2.08
C(2)····H(1)	2.09
C(2)····H(11)	2.09
H(1)····H(11)	1.76
H(1)····H(22)	2.30
H(11)····H(2)	2.30
H(2)····H(22)	1.76

The third group of close intermolecular approaches are listed in Table 11(b). The first four of these involve Cl····C approaches which are slightly less than the Pauling distance of 3.80 Å. No particular significance is attached to these. The remaining four values involve Cl····H contacts. The Cl····H(22) distance of 2.81 Å is very much shorter than the van der Waals distance

Table 11. *Short intermolecular approaches*

(a) Involving a sulphur atom in the central molecule

Atom generated by symmetry	Coordinates of generated atom			Distance
	x/a	y/b	z/c	
S(1)····S(3)	0.3236	0.6024	0.3899	3.67 Å
S(1)····C(2)	0.3250	0.3210	0.1856	3.84
S(2)····C(1)	-0.3921	-0.0723	0.3650	3.83
S(3)····S(1)	0.4467	-0.1001	0.3605	3.67
S(3)····H(1)	0.3643	0.0649	0.5544	2.98
S(3)····C(1)	0.1079	-0.0723	0.1350	3.79
S(3)····H(11)	0.1280	0.0171	0.1750	2.93
S(3)····C(2)	0.3250	0.3250	0.1856	3.82

(b) Other approaches

Atom generated by symmetry	Coordinates of generated atom			Distance
	x/a	y/b	z/c	
Cl·····C(1)	0.1079	0.5723	0.6350	3.73 Å
Cl·····C(2)	-0.1750	0.1790	0.8144	3.73
C(1)····Cl	-0.0086	0.7651	0.4271	3.73
C(2)····Cl	0.0086	0.2651	0.0729	3.73
Cl·····H(2)	-0.1663	0.1688	0.7307	2.88
Cl·····H(22)	0.2317	0.1708	0.6639	2.81
H(2)····Cl	0.0086	0.2651	0.0729	2.88
H(22)····Cl	-0.4914	0.2651	0.4271	2.81

of 3.0 Å. This is interpreted as a strong intermolecular hydrogen bond, the angle $\text{Cl}\cdots\text{H}(22)\text{--C}(2)$ being 159° . The $\text{Cl}\cdots\text{H}(2)$ distance of 2.88 Å constitutes a slightly weaker hydrogen bond, in accord with the reduced angle $\text{Cl}\cdots\text{H}(2)\text{--C}(2)$ of 137° .

The tendency of form hydrogen bonds is related to the electronegativity difference between hydrogen and the other atom. The strength of the hydrogen bond formed decreases from fluorine to oxygen to nitrogen to chlorine to sulphur. Although chlorine has the same electronegativity value as nitrogen, it has a reduced tendency to form hydrogen bonds because of its large size. Nevertheless the hydrogen bonds observed for this compound are real. Each molecule forms two hydrogen bonds to one molecule and two to another molecule, resulting in an infinite chain.

The tendency of crystals to twinning is attributed to the almost symmetrical nature of the molecule, and the similarity in size of Cl and S(3).

Our thanks are due to Professor R. Schmutzler (University of Braunschweig) for suggesting the problem, to Dr S. C. Peake (University of Loughborough) for preparing the compound and to Dr D. R. Russell (University of Leicester) for help with the Stöe diffractometer. We are grateful to Dr F. R. Ahmed and his co-workers (NRC, Ottawa) and Drs W. R. Busing,

K. O. Martin and H. A. Levy (Oak Ridge National Laboratory) for computer programs, and to the staff of the Loughborough University Computer Centre for computing facilities. Finally we wish to thank the Science Research Council for equipment grants and financial assistance to one of us (GWG).

References

- AHMED, F. R., HALL, S. R., PIPPY, M. E. & HUBER, C. P. (1966). NRC Crystallographic Programs for the IBM 360 System, World List of Crystallographic Computer programs, 2nd ed. Appendix p. 52.
- BUSING, W. R., MARTIN, K. O. & LEVY, H. A. (1962). ORNL Report TM-305. Oak Ridge National Laboratory, Tennessee.
- COCHRAN, W. & WOOLFSON, M. M. (1955). *Acta Cryst.* **8**, 1.
- DAUBEN, C. H. & TEMPLETON, D. H. (1955). *Acta Cryst.* **8**, 841.
- DUTTA, S. N. & WOOLFSON, M. M. (1961). *Acta Cryst.* **14**, 178.
- FAVA GASPARRI, G., NARDELLI, M. & VILLA, A. (1967). *Acta Cryst.* **23**, 384.
- HANSON, H. P., HERMAN, F., LEA, J. D. & SKILLMAN, S. (1964). *Acta Cryst.* **17**, 1040.
- HAUPTMAN, H. & KARLE, J. (1953). A.C.A. Monograph I, p. 9.
- HAUPTMAN, H. & KARLE, J. (1959). *Acta Cryst.* **12**, 93.
- KARLE, I. L., HAUPTMAN, H., KARLE, J. & WING, A. B. (1958). *Acta Cryst.* **11**, 257.
- KARLE, I. L. & KARLE, J. (1963). *Acta Cryst.* **16**, 969.
- KARLE, J. & KARLE, I. L. (1966). *Acta Cryst.* **21**, 849.
- KILB, R. W. (1955). *J. Chem. Phys.* **23**, 1736.
- LEE, J. D. & BRYANT, M. W. R. (1969a). *Acta Cryst.* **B25**, 2094.
- LEE, J. D. & BRYANT, M. W. R. (1969b). *Acta Cryst.* **B25**, 2497.
- LEE, J. D. & GOODACRE, G. W. (1969). *Acta Cryst.* **B25**, 2127.
- LEE, J. D. & GOODACRE, G. W. (1970a). *Int. Math. Educ.* **1**, 175.
- LEE, J. D. & GOODACRE, G. W. (1970b). *Acta Cryst.* **B26**, 507.
- LEE, J. D. & GOODACRE, G. W. (1971). *Acta Cryst.* **B27**, 302.
- NARDELLI, M., FAVA GASPARRI, G., GIRALDI BATTISTINI, G. & DOMIANO, P. (1966). *Acta Cryst.* **20**, 349.
- PAULING, L. (1960). *The Nature of the Chemical Bond*, 3rd ed. Ithaca: Cornell Univ. Press.
- SCHOMAKER, V. & STEVENSON, D. P. (1941). *J. Amer. Chem. Soc.* **63**, 37.
- SCHOMAKER, V., WASER, J. R., MARSH, R. E. & BERGMAN, G. (1959). *Acta Cryst.* **12**, 600.
- SUTTON, L. E. (1958). *Interatomic Distances*. Special publication no. 11. London: The Chemical Society.
- VAN DER HELM, D., LESSOR, A. E. JR & MERRITT, L. L. JR (1960). *Acta Cryst.* **13**, 1050.
- WHEATLEY, P. J. (1960). *J. Chem. Soc.* p. 523.
- WILLIAMS, Q., SHERIDAN, J. & GORDY, W. (1952). *J. Chem. Phys.* **20**, 164.
- WILSON, A. J. C. (1942). *Nature Lond.* **150**, 151.
- WOOLFSON, M. M. (1954). *Acta Cryst.* **7**, 61.
- ŽDANOV, G. S. & ZVONKOVA, Z. V. (1950). *Zh. Fiz. Khim.* **24**, 1339.

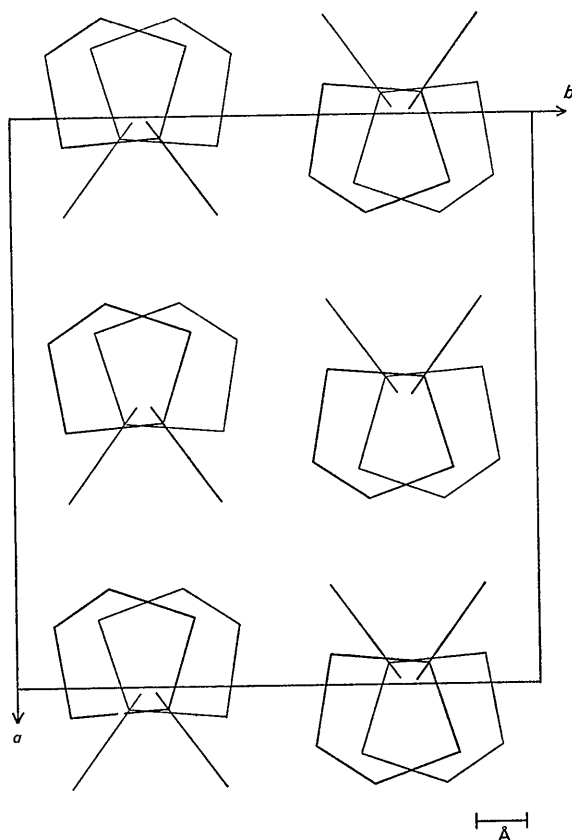

Fig. 2. Packing of molecules in the unit cell as seen down [001].